

RT70/AP
70 LBS THRUST
24 VOLT 42 AMPS
54" OR 60" SHAFT

for use with "WWAF" serial numbers
3-year warranty from the date of purchase

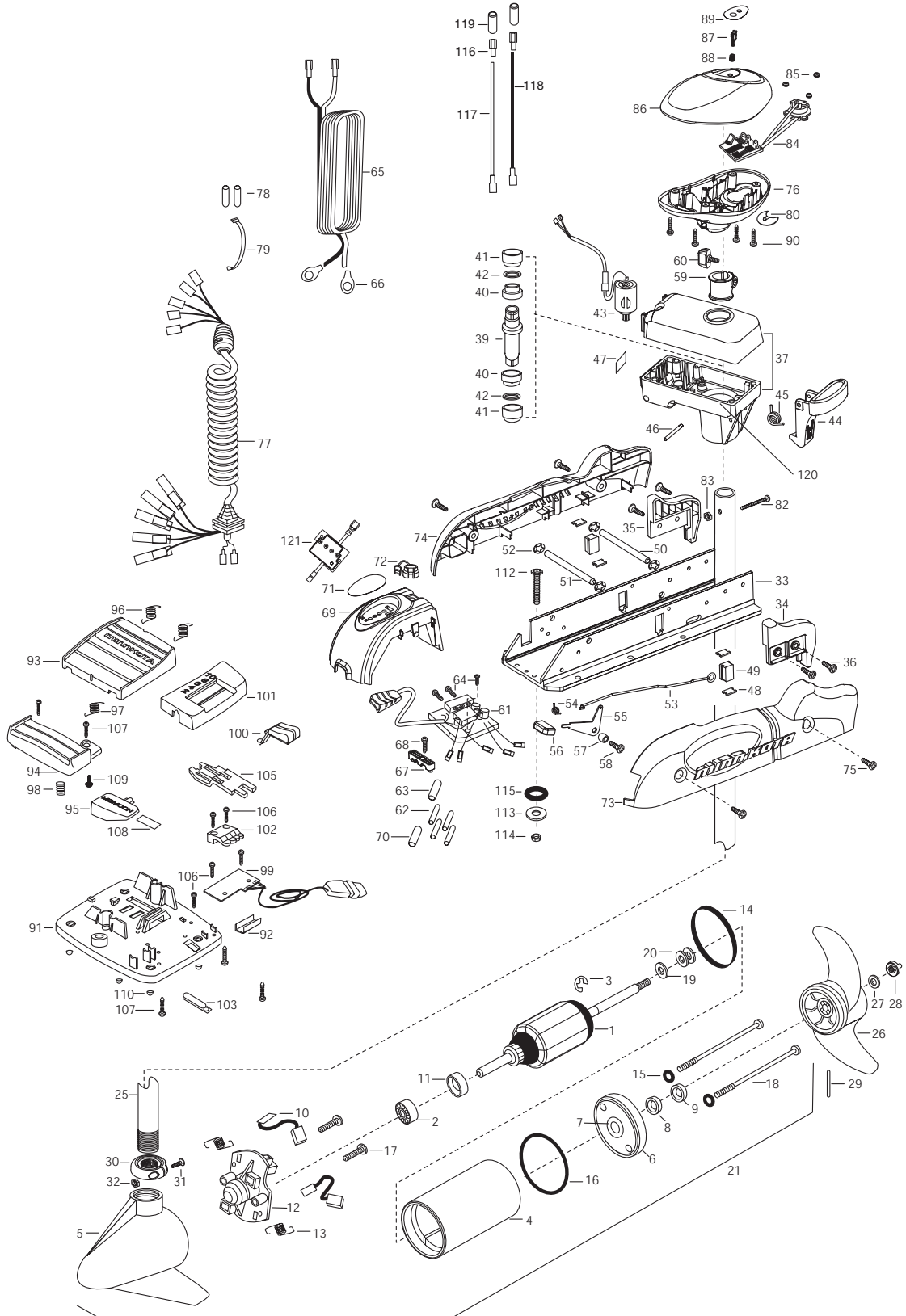

1	2-100-119	ARMATURE ASSEMBLY	43	2307045	MOTOR- DRIVE HOUSING HIGH SPD	85	2302960	GROMMET-COMPASS [3.EA]
2	140-010	BALL BEARING	44	2307205	LATCH HANDLE PD/AP	86	2300243	CONTROL BOX COVER- RT/AP WHITE
3	788-015	RETAINING RING	45	2302750	SPRING- LATCH TORSION PD/AP	87	2304082	ACTUATOR- SWITCH ON/OFF A/P
4	2-200-304	CENTER HOUSING ASSEMBLY 3.62 SW W/MA	46	2302626	PIN- ROLL 3/16 X 2 SS	88	2303752	SPRING- ACTUATOR PD/AP SS
5	421-336	HOUSING BRUSH END 3.62 SW HG TXT	47	2305515	DECAL-STOW/DEPLOY PD/AP 2001	89	2305680	DECAL- COVER ON/OFF RT70/AP
6	2-400-337	PLAIN END HOUSING ASSEMBLY 3.625 SW	48	2335110	PAD-PIVOT SUPPORT SS [4.EA]	90	2372100	SCREW-8-18 X 5/8 SS [4.EA]
7	144-049	BEARING - FLANGE (SERVICE ONLY)	49	2305101	PIVOT PAD [2.EA]	■	2774700	FOOT PEDAL ASSEMBLY
8	880-003	SEAL	50	2330510	PIN-LATCH PD BASE SS	91	2304511	FOOT PEDAL BASE
9	880-006	SEAL WITH SHIELD	51	2330520	PIN-PIVOT PD BASE SS	92	2308500	WEAR PLATE FOOT PDL
10	188-036	BRUSH ASSEMBLY 3.625 [2.EA]	52	2333100	NUT-SPEED SS [4.EA]	93	2304516	FOOT PEDAL-UPPER
11	725-050	BRUSH RETENTION- PAPER TUBE	53	2303612	ROD-RELEASE RT/AP SS	94	2304520	FOOT PEDAL-LOWER
12	738-036	BRUSH PLATE W/HOLDER	54	2302700	SPRING-RELEASE LEVER	95	2307210	LEVER MOM/CON-
13	975-040	SPRING - TORSION [2.EA]	55	2333705	LEVER-RELEASE SS	96	2302730	SPRING-LONG-UPPER PEDAL [2.EA]
14	337-036	GASKET	56	2300101	RELEASE-KNOB	97	2302731	SPRING-SHORT-UPPER PEDAL
15	701-008	O-RING, THRU-BOLT [2.EA]	57	2301700	SPACER-RELEASE LEVER	98	2302732	SPRING-LOWER PEDAL
16	701-081	O-RING	58	2332104	SCREW-1/4-20 X 5/8 SS	99	2304012	CONTROL BOARD ASSEMBLY-FT PDL
17	830-007	SCREW-#8-32 [2.EA]	59	2031522	COLLAR- DRIVE (W/INSERT)	100	2300120	KNOB-SPEED SELECTOR
18	830-008	THRU-BOLT 10-32 X 9.2 [2.EA]	60	2011366	SCREW-COLLAR/NEW KNOB SS	101	2300121	HOUSING SPEED SELECTOR
19	990-067	WASHER- STEEL THRUST	61	2304045	CTRL BOARD ASSEMBLY-24V PD/AP	102	2302840	ACTUATOR-BOARD
20	990-070	WASHER - NYLATRON [2.EA]	62	2305410	SHRINK TUBE-.315 X 2.25 [6 EA.]	103	2302841	ACTUATOR-MOM/CON
21	2096036	MOTOR ASSEMBLY 24V 3.625 VARS 65W	63	2305401	SHRINK TUBE .374 X 1.50 [4 EA.]	105	2302842	ACTUATOR-STEERING
25	2032022	TUBE- COMPOSITE 54" AP WHT	64	2332100	SCREW-8-32 X 3/8 [3.EA]	106	2302100	SCREW-6-20 X 1/2 [5.EA]
	2032023	TUBE - COMPOSITE 60" AP WHT	65	2090601	LEADWIRE 10GA 44"	107	2372100	SCREW-8-18 X 5/8 [5.EA]
■	1378131	PROPELLER KIT(26-29)	66	2020700	TERMINAL RING [2.EA]	108	2266610	DECAL-ON/OFF SWITCH
26	2091160	PROPELLER W/WEDGE 2	67	2222906	STRAIN RELIEF- BRACKET PD/AP	109	2335130	BUMPER ACTUATOR
27	2151726	WASHER-5/16 SS	68	2332104	SCREW-1/4-20 X 5/8 SS	110	2994807	BAG ASSEMBLY- 4 RUBBER BUMPERS
28	2198400	ANODE- ZINC 3.25/3.62 LWR U	69	2306556	HOUSING- CENTER RT/AP WHITE	■	2994812	BAG ASSEMBLY- (BOLT, NUT, WASHERS)
29	2092600	PIN-DRIVE	70	2305415	SHRINK TUBE .472 X 2.25	*112	2333500	BOLT-MOUNTING SS [6.EA]
30	2301555	COLLAR- LATCH PD/AP	71	2306614	DECAL, BATTERY GAUGE H-RT AP	*113	2151726	WASHER-5/16 STD SS [6.EA]
31	2303434	SCREW- 8-32 X 5/8 MACH PHCR	72	2302935	STRAIN RELIEF-DR. HOUSING	*114	2383106	NUT-5/16-18 SS [6.EA]
32	2303112	NUT 8-32 NYLOC SS	73	2303944	SIDEPLATE (RIGHT) WHITE	*115	2301720	WASHER-MOUNTING RUBBER [6.EA]
33	2301933	EXTRUSION- BASE ANODIZED PD/AP	74	2303949	SIDEPLATE (LEFT) WHITE	116	2030710	CONNECTOR BUTT [2.EA]
34	2303932	MOTOR REST- RIGHT LARGE 3 5/8	75	2332104	SCREW-1/4-20 X 5/8 SS[4.EA]	117	2030317	WIRE EXTENSION 18" - RED
35	2303937	MOTOR REST- LEFT LARGE 3 5/8	76	2772516	CONTROL BOX / DECAL ASSEMBLY	118	2030316	WIRE EXTENSION 18" - BLACK
36	2332104	SCREW 1/4-20 X 5/8 SS [4.EA]	77	2991261	COIL CORD WSTRAIN RELIEF AP 54"	119	2375400	SHRINK TUBE 1/4OD X 1-3/4 [2 EA.]
37	2301847	DRIVE HOUSING AP SW WHITE		2991262	COIL CORD WSTRAIN REFIEF AP 60"	120	2304604	O-RING CASE SEAL
■	2882011	BUSHING/ OUTSHAFT KIT (INCLUDES 39-42)	78	2305402	SHRINK TUBE .374 X 2.25 [2 EA.]]	121	2074081	BATTERY METER
*39	2302010	DRIVE HOUSING OUTPUT SHAFT	79	9950433	TIE WRAP-4" BLACK			
*40	2307304	BUSHING- INNER [2.EA]	80	2224701	INSERT- PLUG WHITE			
*41	2307305	BUSHING- OUTER [2.EA]	82	2332102	SCREW-10-24 X 1-3/4 PPH SS			
*42	2304603	O-RING [2.EA]	83	2333101	NUT-HEX 10-24 UNC-2B NYLOC			
			84	2994014	CNTRL BOARD/AP COMPASS ASSEMBLY			

