

MAX65 Ranger
65 lbs Thrust
24 Volt
42" SHAFT

for use with 2005 models with serial numbers less than "MKAF"
3-year warranty from the date of purchase

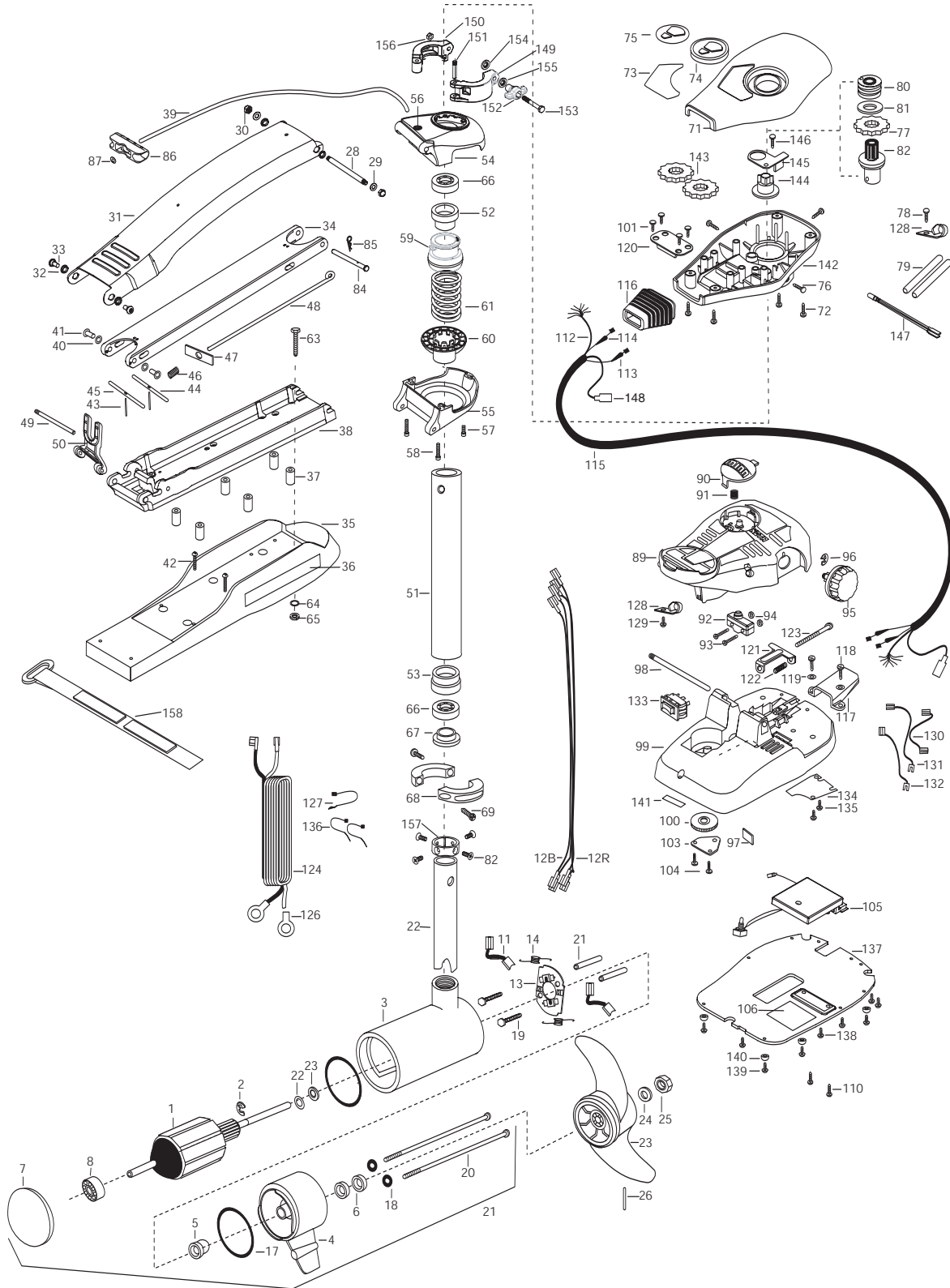

1	2-100-270	ARMATURE ASSEMBLY 24V 4"	51	2272069	TUBE OUTER-21" 4 HOLES	106	2365107	INSULATING PAD (2.3X3.2)
2	788-040	RETAINING RING	52	2266260	BEARING RACE	110	2263448	SCREW- 8-32 X 1" [2.EA]
3	2-200-160	CENTER HOUSING ASSEMBLY 4.0 TXT	53	2266220	BEARING RACE- STEEL	112	2261219	WIRE HARNESS AT & MAX
4	2-300-160	BRUSH END HOUSING ASSEMBLY	■	2991762	BOWGUARD ASSEMBLY- FT CTRL,FW	113	2267500	CABLE ASSEMBLY- RIGHT (5')
5	144-017	BEARING- FLANGE (SERVICE ONLY)	54	2772319	BRACKET BASE TOP/ EYELET ASSEMBLY	114	2267510	CABLE ASSEMBLY- LEFT (5')
6	880-025	SEAL [2.EA]	*55	2991771	BRKT BOTTOM/BEARING FW ASSEMBLY	115	2265430	CABLE JACKET (5')
7	421-241	PLAIN END HOUSING ASSEMBLY	56	2772352	EYELET- KIT	116	2265110	BOOT- CONTROL BOX
8	140-010	BALL BEARING	57	2263423	SCREW 5/16-18 X 1" SHCS ZINC	117	2265115	BOOT- FOOT PEDAL BASE
9	186-094	BRUSH [2.EA]	58	2263425	SCREW 5/16-18 X 2 1/2 SHCS [2.EA]	118	2372100	SCREW- 8-18X5/8 THD [2.EA]
10B	640-017	LEADWIRE-BLACK 10 AWG 61 XLP	59	2071541	SPRING SLEEVE- UPPER	119	2261714	WASHER- MAXXUM FT PDL [2.EA]
10R	640-121	LEADWIRE-RED 10 AWG 62 1/2	60	2071535	SPRING SLEEVE- LOWER	120	2261901	BRACKET- CONDUIT
12	738-040	BRUSH PLATE 4"	61	2262712	SPRING- BOWGUARD, NIK PL	121	2263210	BRACKET- CONDUIT ADJUST
13	975-041	SPRING- TORSION [2.EA]	■	2994830	BAG ASSEMBLY- MAXXUM	122	2262720	SPRING- CONDUIT ADJUST
14	701-009	O-RING —THRU BOLT [2.EA]	*63	2263431	SCREW- 1/4-20 X 3.5 PPH [6.EA]	123	2263463	SCREW- 1/4-20X2" STL PPH
15	701-043	O-RING [2.EA]	*64	2261713	WASHER- 1/4 FLAT S/S [6.EA]	124	2261227	LEADWIRE- A/T VARIABLE
16	830-027	SCREW -SELF THREAD 10-32X2 [2.EA]	*65	2263103	NUT- 1/4-20 NYLOCK-JAM SS [6.EA]	126	2020700	TERMINAL RING- 3/8" [2.EA]
17	830-094	THRU BOLT 12-24X10.31 [2.EA]	66	2266000	BEARING BALL- STEEL [2.EA]	127	2256300	TIE WRAP- 5.5' BLACK
18	973-025	SPACER- BRUSH PLATE [2.EA]	*67	2266115	BEARING CONE	128	2263201	CLAMP WIRE HARNESS MICRO [2.EA]
19	990-051	WASHER- STEEL	*68	2261619	COLLAR HALF- ZINC [2.EA]	129	2332103	SCREW- 6-20X3/8 THD (SS)
20	990-052	WASHER- NYLATRON	*69	2263452	SCREW- 1/4-20X3/4 [2.EA]	130	2260316	CONNECTING WIRE (VAR.SPD)
21	2319253	MOTOR ASSEMBLY 24V F/W	71	2260283	CONTROL BOX COVER- MAXXUM	131	2260312	WIRE- BLK W/WHT STRP 19 -1/4"
22	2032003	TUBE- COMPOSITE W/4 HOLE 42"	72	2372100	SCREW- 8-18 X 5/8 THD [4.EA]	132	2260323	WIRE- BLK W/GRN STP VARIABLE
■	1378129	PROPELLER KIT	73	2265620	DECAL- COVER MAX65/FC	133	2254031	SWITCH- MOM/OFF/CON
23	2331120	PROPELLER W.WEDGE	74	2260150	POINTER DISC TRNSLCNT RED	134	2266412	SWITCH PLATE- FT PEDAL
24	2091701	WASHER- SS	75	2265800	DECAL- INDICATOR	135	2332103	SCREW- 6-20X3/8 THD SS [2.EA]
25	2093101	NUT-PROP NYLOC	76	2053414	SCREW- 8-32 X 1/2 TRI-LOBE [3. EA]	136	2256301	TIE WRAP- 5.5" WHITE [2.EA]
26	2092600	PIN-DRIVE	77	2267800	GEAR- INDICATOR	137	2774511	BOTTOM PLATE- MAXXUM FT
28	2262605	PIN- BWGRD UPPER THREADED ZP	78	2301310	SCREW- 8-18 X 1/2	138	9953104	SCREW-8 X 1/2" (SS) [5.EA]
29	2261722	WASHER- FLAT [2.EA]	79	2355410	SHRINK TUBE- 3/8 OD X 2" [2.EA]	139	2263455	SCREW- #12-14X1/2 THR FRM [4.EA]
30	2223100	NUT- TENSION 5/16-18 SS [2.EA]	80	2232360	PULLEY- CABLE DRUM	140	2265126	BUMPER PAD- FOOT PEDAL [4.EA]
■	2771840	MOUNT- BOW ASSEMBLY, STD FW MAX	81	2261730	WASHER- NYLON A/T CON	141	2266610	DECAL- ON/OFF SWITCH
31	2264241	ARM-UPPER STD FW	82	2996247	TOP BEARING RACE /PINION DRIVE	142	2262535	CONTROL BOX- PLASTIC
32	2293501	BUSHING- STAINLESS STEEL [4.EA]	83	2223468	SCREW- 8-32 X 7/16 [4.EA]	143	2267800	GEAR- INDICATOR [2.EA]
33	2263500	BOLT- SHOULDER MAXXUM [2.EA]	84	2262607	PIN- CLEVIS ZP MAXXUM BWGRD	144	2262220	INDICATOR- DRIVE
34	2774315	ARM-LOWER ASSEMBLY,STD,FW,EXTRA [INCLUDES 39, 43-47, 86,87]	85	2260805	CLIP- SPRING ZP MAX BG	145	2261905	BRACKET/INDICATOR
			86	2150400	PULL- GRIP	146	2301310	SCREW- 8-18X1/2"
35	2263912	MOTOR REST (STD) FW	87	2151700	WASHER- EYE SHAFT(.562 OD)	147	2264015	LIGHT/INDICATOR
36	2265514	DECAL- MAXXUM MOTOR REST [2.EA]	89	2790002	FOOT PEDAL/PLUG ASSEMBLY	148	2211400	EXTENSION CABLE- SONAR
37	2261505	SPACER- MOTOR REST [6.EA]	90	2263700	PUSH- BUTTON FOOT PEDAL	■	2991550	CLAMP COLLAR ASSEMBLY
38	2773987	BOWPLATE- W/INSERT	91	2302732	SPRING- LOWER PEDAL	149	2071550	CLAMP COLLAR "A"
39	2251601	ROPE (40"), MAXXUM MOUNT	92	2264023	SWITCH- SEALED ASSEMBLY	150	2071555	CLAMP COLLAR "B"
40	2261708	WASHER- 3/8X1/2X.010 SS [2.EA]	93	2262114	SCREW- MOUNTING/SWITCH [2.EA]	151	2072621	PIN-KNURLED
41	2236000	BEARING NYLINER [2.EA]	94	2233100	NUT- SWITCH MOUNT [2.EA]	152	2070120	KNOB-CLAMP COLLAR
42	2263434	SCREW, 8-18X1" PPH [2.EA]	95	2260160	KNOB- SPEED CONTROL (VAR)	153	2073412	SCREW 1/4-28 X 2 3/4" SS
43	2152610	SPRING- PIN LOCKBAR [2.EA]	96	2263000	E-RING THU-ARC	154	2071718	WASHER #10 NYLON RETAINING
44	2233600	LOCK BAR- BOW MOUNT	97	2266413	TENSION SCREW PLATE FTPEDAL	155	2071716	WASHER - FLAT SS
45	2233602	LOCK BAR REAR - ZINC	*98	2260511	PIN- PIVOT A/T FT PDL	156	2073102	NUT - HEX 1/4 - 28 SS
46	2152700	SPRING- LOCKBAR CAD.PLTD	99	2774550	FT PEDAL BASE/PIN ASSEMBLY	157	2071560	SPLIT COLLAR
47	2262703	SPRING STOP- MAXXUM	100	2262301	PULLEY- FOOT PEDAL	158	2263804	STRAP - VELCRO 30.5"
48	2153602	EYE SHAFT-2LOCKBAR STD	101	2223430	SCREW- #8X3/4 PPH TYPE 25 SS [4.EA]			
49	2260506	HINGE-PIN HEADLESS ZINC	103	2266400	COVER- PULLEY			
50	2293811	YOKE- MAXXUM MOUNT,POLYPROPYLENE	104	2301310	SCREW- 8-18 X 1/2 [4.EA]			
■	2772012	TUBE W/BEARING RACE ASSEMBLY	105	2264038	CNTROL BOARD ASSEMBLY 24V MAX65/FC			

Seal & Oring Kit P/N 2889460

* This item is part of an assembly. This item cannot be sold separately due to machining and /or assembly that is required.

P/N 2274940 REV. A 7-04

